

15.6" TFT Fanless Touch Panel Computer with Intel® Whiskey Lake i5-8265U 1.6GHz Quad Cores Processor

Features

1. 15.6" 250 nits TFT LCD with LED backlight
2. 10-points Multi Capacitive Touch
3. Support Open frameless design
4. A true Flat, easy-to-clean front surface with edge-to-edge design
5. Front IP65 for protection against water and dust
6. 9-24V DC-input Support, with EOS, OVP design
7. VESA Support 100x100mm



IO Diagram

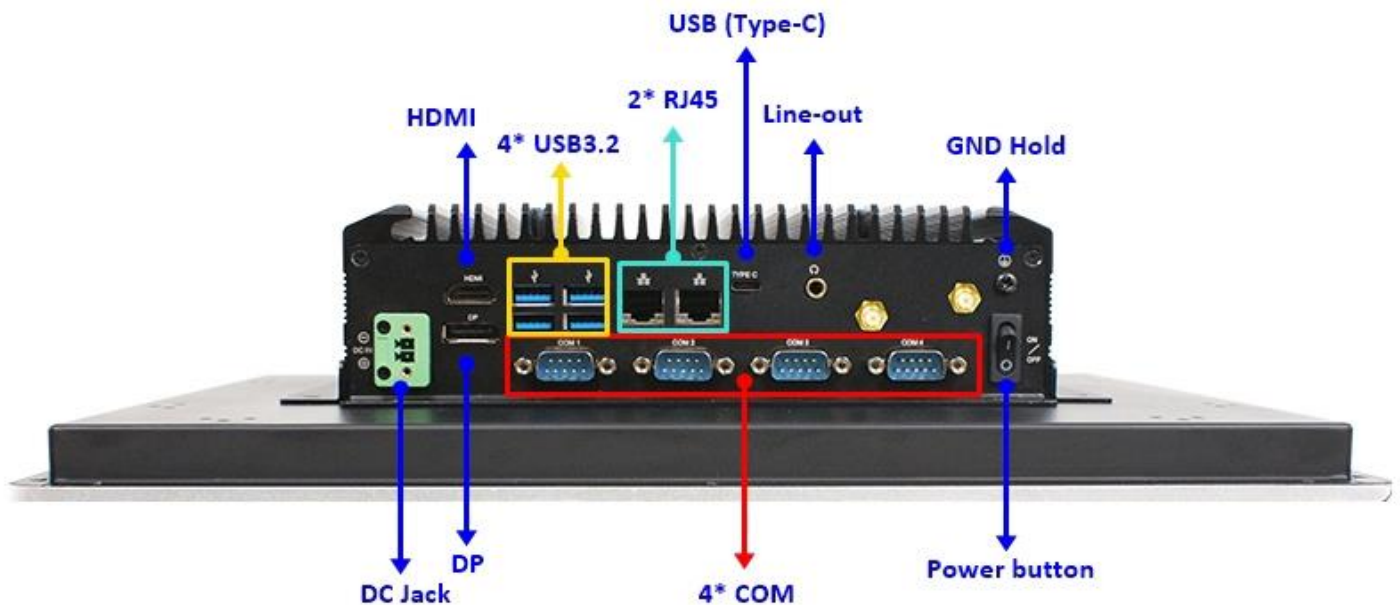

Specifications

Model

HPC156BC-FP8265

Display

- IP65, NEMA 4 rugged protection, metal front bezel
- 15.6" With LED Backlight
- 250 nits
- 262K display color
- 1920 x 1080 @60Hz resolution
- 170°/170° viewing angle (H/V)
- 0.17925 x 0.17925mm pixel pitch
- 16:9 aspect ratio
- 800:1 contrast ratio
- 35ms response time

I/O Connector

- 4* USB3.2
- 1* TYPE-C (USB3.2, Gen2)
- 1* RS232/422/485
- 3* RS232
- 1* HDMI
- 1* DP
- 2* RJ45 (1* Intel® I211AT GbE, 1* Intel® i219-LM GbE)
- 1* Line-out
- 1* Locking Jack 9~24V DC input
- 1* Power button
- 1* GND Hold

Expansion

1* M.2 E key (2230) for WIFI

Power

- AC version: 100~240V AC-DC 60W power adapter or
- DC version: 12VDC with over current protection fuse
- Consumption: 43W

Safety

- Shock: 1ms duration
- Vibration: 5~500Hz/1 Grms

Temperature

- Operating Temperature: -10 ~ 50° C
- Storage Temperature: -20 ~ 70° C
- Humidity: 10% ~ 90% RH @40°C (non-condensing)

* Specifications subject to change without notice, not responsible for typographical errors. Does not include HDD or OS.

Main System

- Intel® Whiskey Lake i5-8265U 1.6GHz/QC processor
- 2* DDR4 SO-DIMM (Max 32GB)
- 128MB SPI Flash ROM
- Watchdog Timer 256 levels, 0~255 sec.
- OS Support Windows 10 / Linux

Touch Screen

- Projected capacitive type
- 346.0 x 194.5mm ±0.3mm active range
- Transparency ≥85%
- Surface Hardness ≥6H (JIS-5400)

Storage

- 1* 2.5" SATA HDD (UPS Cell Option)
- 1* M.2 M key (2242/2280, NVMe)

Case

- Aluminum panel
- Iron case
- Black color
- Spray paint coating requirement

Compliance

CE, FCC, IP65 (Front), Option

Dimensions

398.81 x 249.12 x 83.80mm

Warranty

2 Years Limited Warranty (Panel and Touch is only Warranty 1 Year)

Mechanical Drawings (Unit=mm)

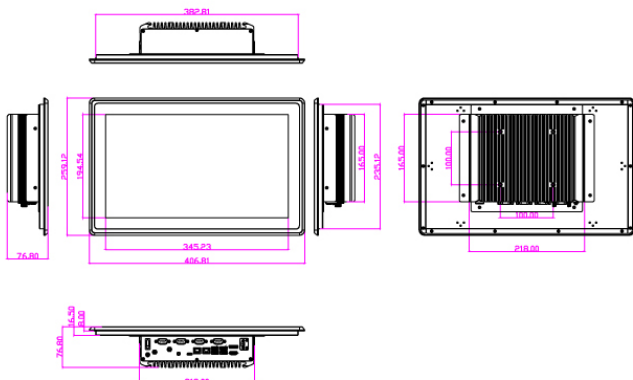

Standard Accessories

Part Number	Description
	HPC156BC-FP8265
	Power cord
	90W AC-DC Adapter
HPC-HBD (option)	6* Mounting Clips

HPC-HB Mounting clips for 7", 8", 10.1" Panle PC

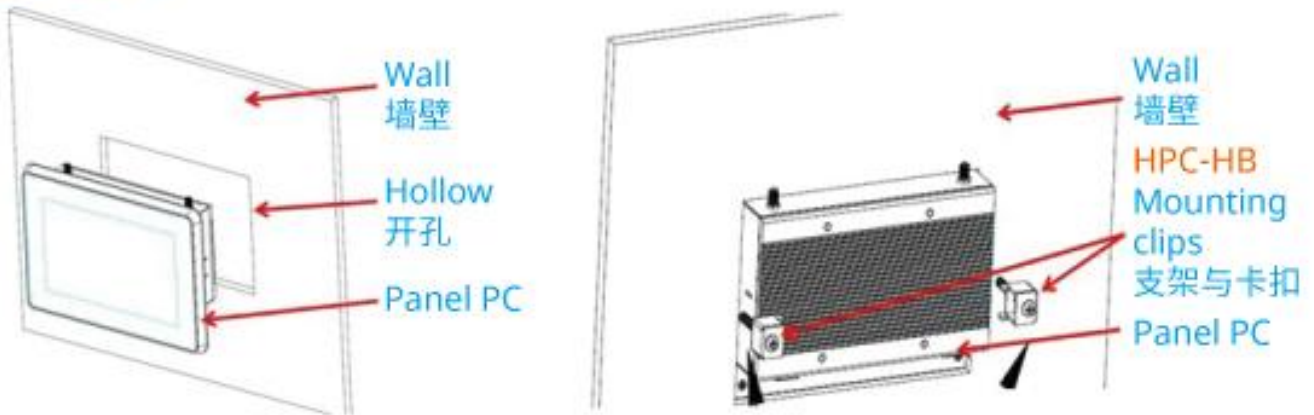

HPC-HBD Mounting clips for 10.4", 15", 15.6", 17", 18.5", 21.5", 23.8" Panle PC

