



HBJC501F9Q(W)-Q87-B



1. Intel LGA 1150 Socket Core i3/i5/i7 Processors(35W)
2. 2 * SO-DIMM Dual CH DDR3 1600MHz up to 16GB
3. 2 * USB2.0, 4 * USB3.0, 5 * COM, 1 * DVI, 1 * HDMI, 2 * RJ45
4. M/B Form Factor : Mini ITX (170x170mm)



External I/O

Rear

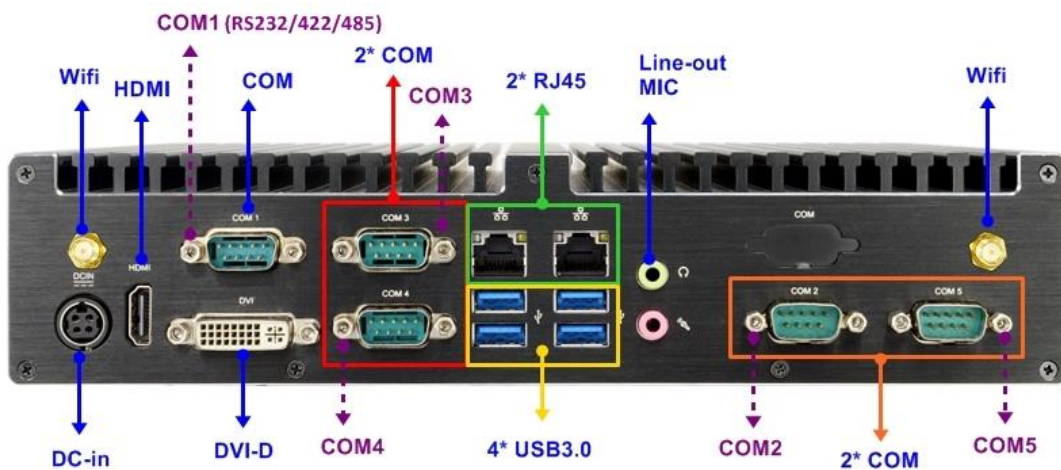

Front



Specifications

MB Model	JNF9Q-Q87 / Mini-ITX
Part No	● HBJC501F9Q-Q87-B (non-WIFI) / HBJC501F9QW-Q87-B (WIFI)
BIOS	AMI Flash ROM
CPU/Chipset	● INTEL® LGA 1150 Socket Core i7/i5/i3/Pentium Processor (35W) ● INTEL® Q87 express chipset
Memory	2 * 204-pin SO-DIMM slots supporting dual channel DDR3-1600 up to 16GB max
Storage	● 1 * 2.5" SATA3 6Gb/s internal drive bay (only support 2.5" HDD with a hight ≤ 10mm) ● 1 * Full-size mSATA/mini-PCI Express shared slot
Network	● 1 * Intel i211AT Gigabit LAN, 1 * Intel i217LM Gigabit LAN with vPro & iAMT 9.0 support ● 1 * Half-size mini-PCIE slot (802.11 b/g/n + BT 4.0 installed in WIFI model)
Rear Panel I/O	● 4 * USB 3.0 ports ● 1 * HDMI (Max. Resolution:1920×1200@60Hz) ● 1 * DVI-I (Max. Resolution:1920×1200@60Hz) ● 2 * RJ45 ● Line-out, Mic-in ● 5 * COM (1 * RS232/422/485, 4 * RS232) ● 2 * Antenna holes (HBJC501F9QW-Q87-B only) ● DC-In jack
Front Panel I/O	● 1 * Power button, 1 * HDD LED ● 2 * USB 2.0 ports
Power Source	● AC 90~240V input / 120W AC-DC Adapter_DC19V-6.32A / LEVEL6
Compliance	CE , FCC
Environment	Operating Temperature: -20 ~ 50 °C (The test environment is closed and windless) Storage Temperature: -20 ~ 85 °C Humidity : 90% , non-condensing
Dimensions	264 (W) x 199.4 (D) x 58 (H) mm
Packing	● Net Weight: 4.2KG ● Gross Weight: 5KG ● Color Box dimension: 406 (W) * 148 (D) * 380 (H) mm
OS Support	Windows 7, Windows 8.1, Windows 10, Linux
Warranty	2 Year limited warranty

*Specifications subject to change without notice, not responsible for typographical errors. Does not include HDD or OS.

Part Number Rule



Mechanical Drawings (Unit = mm)

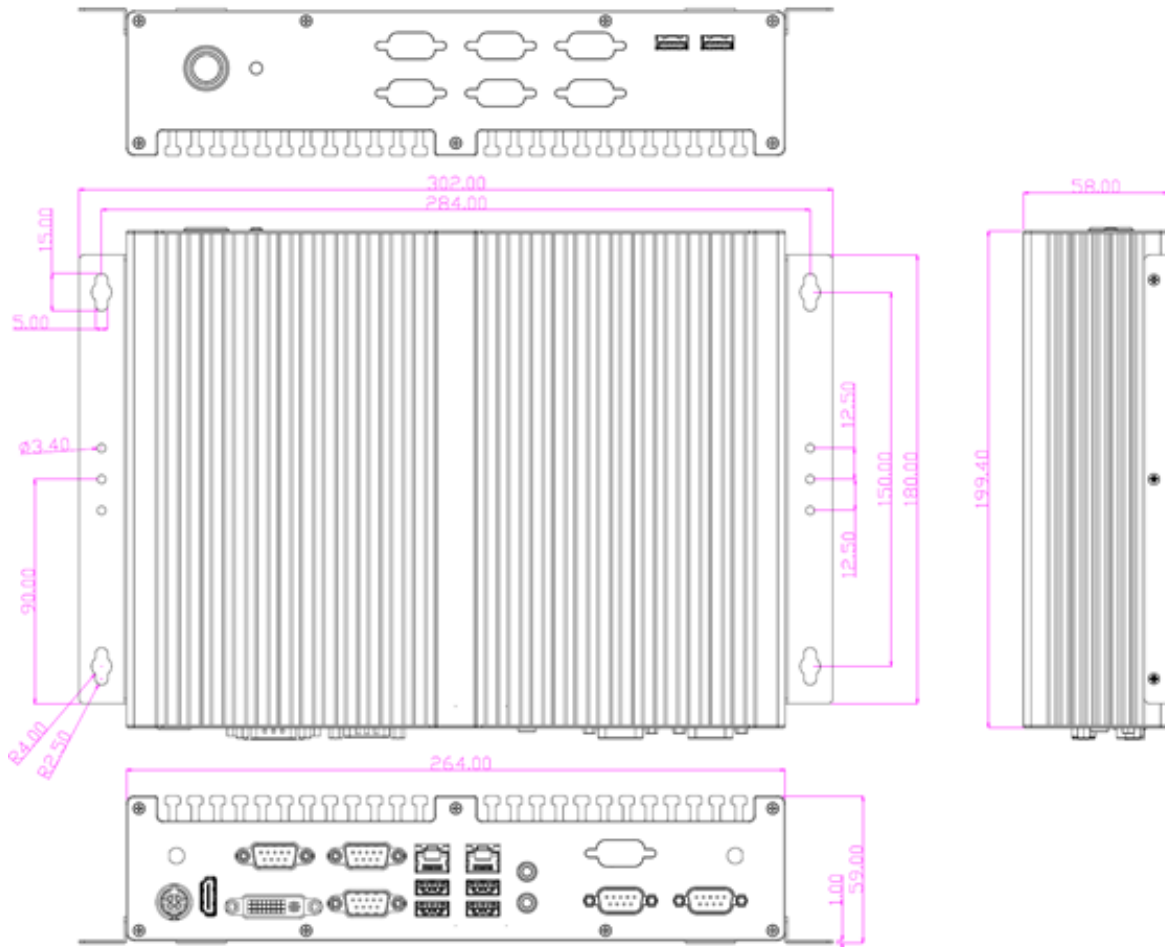

Accessories

Parts Number	Description
-----	HBJC501F9QU(W)-Q87-B
G01-DVI-VGA-W-F	DVI to VGA adapter
L01AS056-F	Adapter 19V/6.32A 120W
Change according to shipping area	Power cord
HCS5XXMWM01B-F	JC5XX Wall mount / Black color
LCSCHBJC3XX-F	Screw Pack
J05-ANT-AN2400-F	Antenna2G4 -2dBi R-AN2400-5701RS (HBJC501F9QUW-Q87-B only)
HCS3XXDINRAILPS-F	Din Rail Clip

Tel: +886-2-89132711 E-mail: sales@jetway.com.tw Web: www.jetwayipc.com
Support: technic_support@jetway.com.tw or support_team@jetway.com.tw